

SOTABEAMS dsPIC Development Module

Thank you for buying our development board. It has been designed to give you sufficient flexibility to allow the development of your own dsPIC projects.

A ready-built module designed as a flexible platform for developing your own dsPIC code using the powerful 16 bit [dsPIC33FJ64MC804-I/PT](#). Module has full ICSP header and I2C with on-board switch and LED. AF input (1) is protected. Many other connections are brought out for maximum flexibility. 64KB flash + 16KB RAM gives plenty of room for software development.

The module plugs neatly into a breadboard for easy use. Programmable with the cost-effective PICkit 3 system from Microchip.

Use Microchip's extensive software libraries and free tools to develop your own code!

TM

The Module is supplied unprogrammed. You will need a pic programmer to make use of it. The Microchip PICkit 3 is ideal. This is connected to the ICSP header on J4.

Microchip provide a complete free programming environment and a library of code snippets that will get you up and running. Their website is <http://www.microchip.com/development-tools>

The following diagram shows the layout of the development module:

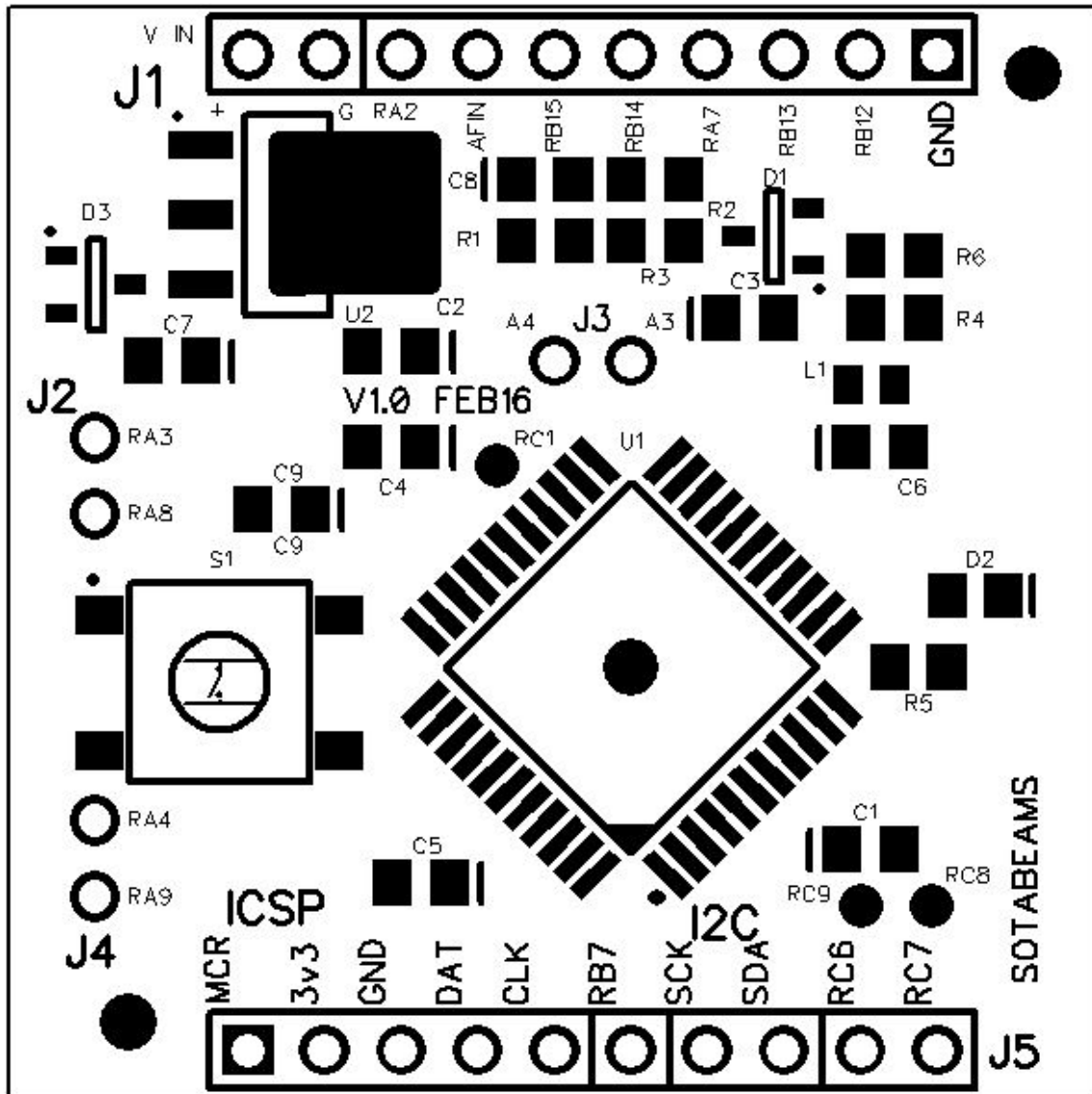

The pins are labelled on the board. The headers are for standard pitch header pins and with J1 and J5 installed, the board will sit neatly across a breadboard. Connect your supply (5-14 volts) between J1(10) = +ve and J1(9) = GND. The I2C pins will need pull-ups for use. The switch is between RB4 and ground. The LED is connected to RA10. Audio input is on RA0.

A circuit diagram of the board is at www.sotabeams.co.uk/content/FDB.dxf

If you don't have any software able to read DXF files, a good online one is at:

<https://gallery.proficad.com/tools/AutoCAD-Viewer.aspx>

Support

We cannot provide support for your software development but if you have any questions about the hardware, we will be pleased to assist. For software support, we recommend the various Microchip forums.